

ECONOMICAL THERMAL MASS FLOW SENSOR BASED ON CONSTANT TEMPERATURE ANEMOMETRY

Lötters, Joost
Bronkhorst High-Tech B.V
Nijverheidsstraat 1a, 7261 AK Ruurlo, The Netherlands
E-mail: JCLotters@Bronkhorst.com

Manger + Wittmann, Elektronische Gasmess-technik GmbH
Gutenbergstraße 7, D-85748 Garching b. München, Germany
Phone: +49-89-3294590, Fax: +49-89-32945985; E-mail: Verkauf@Manger-Wittmann.com

INTRODUCTION

The mass flow meters and controllers (MFM's and MFC's) from Bronkhorst High-Tech's EL-FLOW series are renowned for their high accuracy and competitive price. However, there is an increasing demand from the market for mass flow meters that

- have low pressure drop
- are economically priced
- have medium accuracy

Manger + Wittmann's Mass-Stream D-6200 series of mass flow meters will provide the right solution for the requirements of the market. Features of the D-6200 series of MFM's are:

- simple and robust design
- no bypass, relatively low pressure drop
- direct measuring of 'point' mass flow

Typical applications of the D-6200 series MFM's are

- gas consumption monitoring (e.g. for accounting purposes)
- process control (e.g. in burner systems, analysers)
- medical gas monitoring (e.g. anaesthetic delivery)

In this paper, the sensor structure and basic operating principle of the D-6200 MFM, its heat transfer, the electronic circuitry, the output voltage for a certain flow range and the conversion factor for different gases will be described. Some measurement results will be presented and discussed, and finally some conclusions will be drawn.

THE DIFFERENCE BETWEEN BYPASS AND DIRECT MASS FLOW MEASUREMENT

The operation principle of Bronkhorst High-Tech's EL-FLOW series Mass Flow Meters and Controllers is based on the *Bypass Mass Flow Measurement Principle*. According to the bypass measurement principle as shown in figure 1a, a certain known part of the flow is directed through a bypass channel, around which the flow sensor is placed. Thus, the flow is measured *indirectly*. On the other hand, the flow can be measured *directly* with the *Direct Mass Flow Measurement Principle*. In this case, as depicted in figure 1b, the flow sensor is put straight into the flow channel, thus making the bypass channel obsolete. Another name for this measurement principle is *Anemometry* (or *Hot Wire Anemometry* (HWA) in the case of a thermal direct mass flow meter [1]). An example of a Mass Flow Meter which operation principle is based upon the Direct Mass Flow Measurement Principle is Manger + Wittmann's D-6200 series.

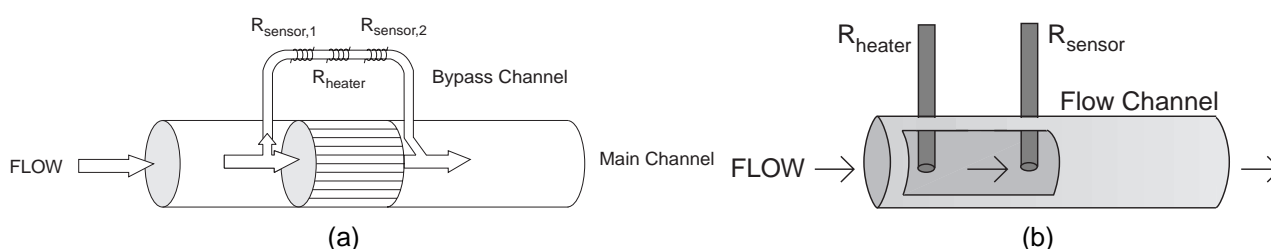

Figure 1. Bypass (a) and Direct (b) Mass Flow Measurement Principle

SENSOR STRUCTURE

The actual flow sensor in the D-6200 Mass Flow Meter, as shown in figure 1b, consists of a heater resistor and a temperature sensing resistor. Both resistors are made of temperature sensitive resistive material that is covered with a stainless steel tube.

As shown in figure 2a, the two sensor legs are put through two small holes in the body. Thus, they are both in contact with the flow and mechanically connected to the body. For each flow range, the inside diameter of the flow tube is changed in such a way that the flow velocity remains at its nominal value at 100 % flow under nominal conditions, $T = 20^{\circ}\text{C}$ and $p = 1$ bar. Finally, the two resistors of the flow sensor are connected to the electronic circuitry, as schematically drawn in figures 2b and 2c.

BASIC OPERATING PRINCIPLE

By directing a current through it, the heater's temperature is increased to approximately 30°C over ambient temperature. The sensor resistor measures ambient temperature and is used for temperature compensation. The heater and sensor resistors are electrically connected via a Wheatstone bridge configuration, as shown in figures 2b and 3. The Wheatstone bridge configuration should be carefully designed because it has two features: first, it provides the heater with the necessary heater current and the sensor with the measuring current and second, it takes care of the temperature compensation. When the equilibrium of the bridge is disturbed, i.e. the temperature difference between heater and sensor is not equal to approximately 30°C anymore, the bridge will produce an error voltage. This error voltage causes the PI controller to adapt the heater current in such a way that the equilibrium of the bridge will return swiftly and smoothly.

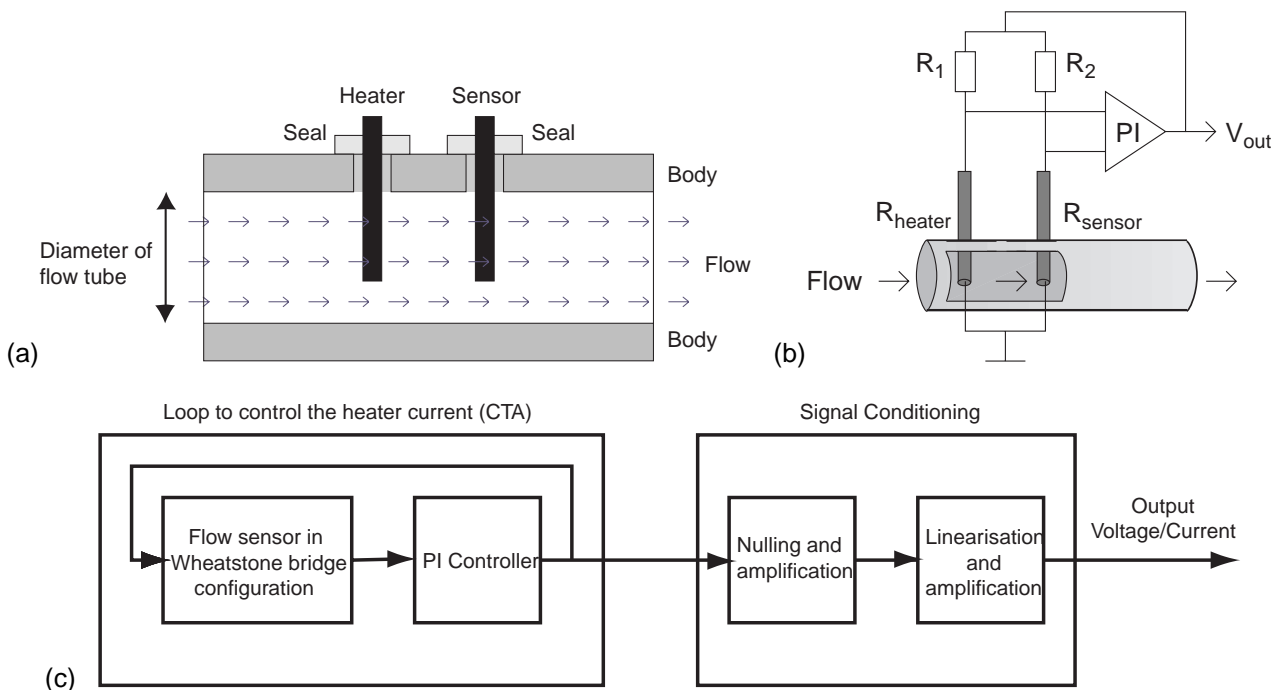

Figure 2. D-6200 flow sensor (a) placed in the flow channel and thus connected to the body, (b) connection of the two flow sensor resistances to the electronic circuitry, and (c) block diagram of the thermal mass flow sensor and electronic circuit

The necessary heating power to keep the temperature difference between heater and sensor at a constant level appears to be dependent on the mass flow. In the case of no flow, a constant and relatively small heating power is necessary. This constant 'threshold value' is called the *offset* heating power. When a certain mass flow occurs, the heater is cooled down by *forced convection* due to the gas flow. Therefore, the heating power has to be increased to maintain the established temperature difference. Thus, a different and unique heater current is produced for each value of the flow. The measurement principle described is called *Constant Temperature Anemometry (CTA)*.

HEAT TRANSFER

At the beginning of this century, King extensively examined a number of features of the direct flow measuring principle. He formulated an expression, known as *King's law*, in which heating power and mass flow are related. Using King's law, the necessary heater power can be equated with [1]

$$P_{heater} = P_{offset} + C \cdot \Phi_m^n \quad (1)$$

with P_{heater} [W] = $I_{heater}^2 \times R_{heater}$ the power dissipated in the heater, I_{heater} [A] the current through the heater, R_{heater} [Ω] the heater resistance, P_{offset} [W] the offset heater power at no flow, C a proportional constant which takes a.o. the heater dimensions and gas properties into account, Φ_m the mass flow and n [-] a dimensionless factor depending on the Reynold's number (in most cases, $n \sim 0.25$). It is important to note that also the offset heater power is dependent on a number of gas properties. This means that a zero shift will occur when a different gas is applied!

Nominally, the over temperature of the heater is approximately 30 °C and the control loop makes sure that this value is maintained by providing the heater with the necessary heater current. When no flow occurs, the heater power is equal to P_{offset} . In this case, *radiation*, *conduction* and *free convection* cause heat loss to the environment. When a certain flow occurs, the heater power will increase according to equation (1). In that case, the heat loss to the environment is caused by *radiation*, *conduction* and *forced convection*. The heater power as a function of all previously mentioned heat loss mechanisms can generally be calculated with

$$P_{heater} = \alpha A_1 \Delta T + \lambda A_2 \frac{dT}{dz} \quad (2)$$

with α [W/(m²K)] the heat transfer coefficient (determined by the gas properties c_p [J/(kg.K)], ρ [kg/m³], λ [W/(mK)] and μ [Pa·s], heater dimensions and heat transfer mechanism), A_1 [m²] the area of the heater surface, ΔT [°C] the over temperature of the heater, λ [W/(mK)] the heat conduction coefficient of the material of the heater, A_2 [m²] the heater leg's 'conductive area' and dT/dz [K/m] the gradient of the temperature profile in the heater's leg in the direction of the body. Expressions for α and dT/dz can either be directly found in literature [1 – 4] or have to be derived for this specific case.

ELECTRONIC CIRCUITRY

Block diagrams of the D-6200 mass flow meter and its excitation/read-out electronics are shown in figures 2c and 3. The electronic circuitry can be divided into two main functional blocks. Namely, the *control loop*, which regulates the heater current as a function of the occurring flow, and the *signal conditioning circuitry*, which makes sure that the output voltage or current develops linearly with the flow.

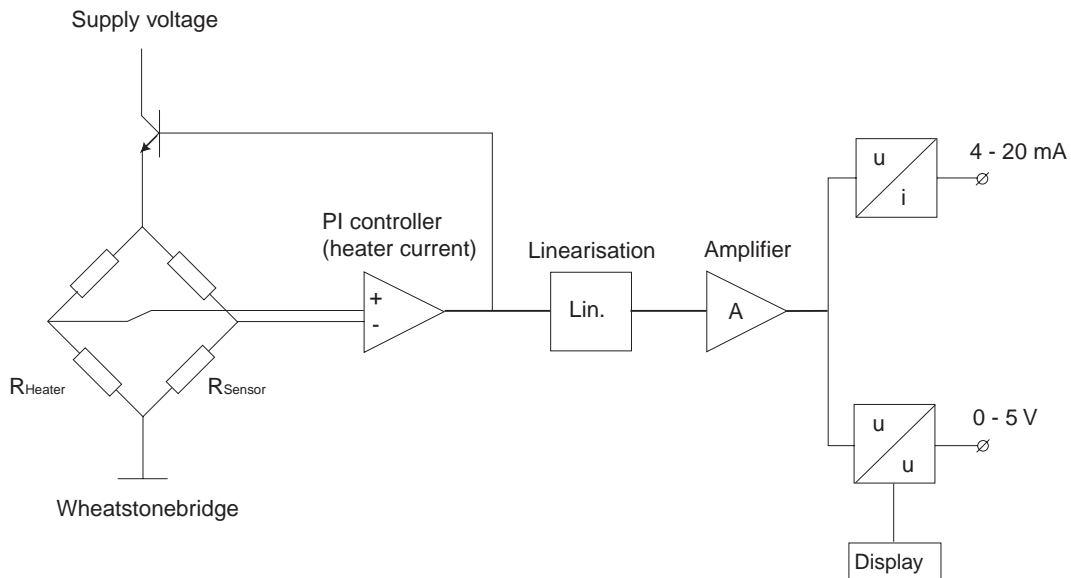

Figure 3. Block diagram of the M+W mass flow sensor and electronic circuit

Most important part of the electronic circuitry is the control loop, which ensures that the heater is provided with extra current to compensate for the heat loss due to forced convection, as described in the previous section. The control loop comprises the two sensing resistances in a Wheatstone bridge configuration and a PI controller for an optimum response.

The signal conditioning block converts the occurring non-linear heater current into an output voltage or current which varies linearly with the flow, in the range 0 – 5 V or 4 – 20 mA, respectively. To reach this goal, the circuitry comprises an offset nulling, linearisation and amplification stage.

OUTPUT VOLTAGE

The heater power has to be converted into a useful output signal with the aid of the electronic circuitry. In the circuit, the heater power is first converted into a measuring voltage (which is as non-linear as the heater power itself) then the offset voltage due to the offset power is eliminated (the true zero is suppressed!) and finally the voltage is linearised. The resulting output voltage V_{out} [V] can now be calculated with

$$V_{out} = K \cdot \Phi_m \quad (3)$$

with K a constant in which a.o. the heater dimensions, the gain factor of the electronic circuitry and the gas properties λ [W/(mK)] the heat conduction of the gas, c_p [J/(kgK)] the specific heat, μ [Pa·s] the dynamic viscosity and ρ [kg/m³] the mass density are taken into account, and Φ_m [kg/s] the mass flow of the gas.

CONVERSION FACTOR

A D-6200 Mass Flow Meter can be applied for most gas types. Since it is rather impractical to perform an actual calibration for each gas, it would be easy if all calibrations could be performed with air. Therefore, it is necessary to know the relation between air and the gas under calibration. This relation is given by the Conversion Factor (CF). Using equation (3) the conversion factor can be calculated with

$$CF = \frac{V_{out,AIR} |_{\Phi_m=C}}{V_{out,GAS} |_{\Phi_m=C}} = \frac{K_{AIR}}{K_{GAS}} \quad (4)$$

In table 1, a list of calculated Conversion Factors of some gases is given.

Air	1.00	C ₂ H ₂	0.75
Argon	2.01	C ₃ H ₈	0.63
CO ₂	1.24	CH ₄	0.67
Helium	0.23	CO	1.04
H ₂	0.15	C ₂ H ₄	0.89
NH ₃	0.80	NO	1.02
N ₂ /O ₂	1.00	HCl	1.58

For example, the Conversion Factor (CF) of Argon is equal to 2.01 at $T = 20$ °C and $p = 1$ bar. So, the equivalent of 100 l_r/min air = 100 × 2.01 = 201 l_r/min argon. Subsequently, the equivalent of 100 l_r/min argon = 100 / 2.01 = 49.7 l_r/min air.

EXPERIMENTAL

Several D-6200 mass flow meters have been built for different ranges, varying between 5 and 2000 l_r/min. The instruments have been thoroughly tested for different gases at all important features, such as linearity, resolution, inaccuracy, response time, repeatability, stability, (temperature) drift, pressure drop and -dependency, power consumption and EMC compatibility.

The conversion factor check was performed on an instrument suited for 50 l_r/min AIR. First, this instrument was calibrated such that a mass flow from 0 up to 50 l_r/min AIR resulted in a linearly varying output voltage from 0 up to 5 V. The settings of the instrument were not adjusted during the experiment (except for helium and hydrogen, which both cause a large zero shift)! Then, several other gases, like nitrogen, argon, helium, hydrogen and carbon dioxide, were applied to the instrument and its output voltage was measured.

RESULTS AND DISCUSSION

The measurement results of the conversion factor check are displayed in figure 4.

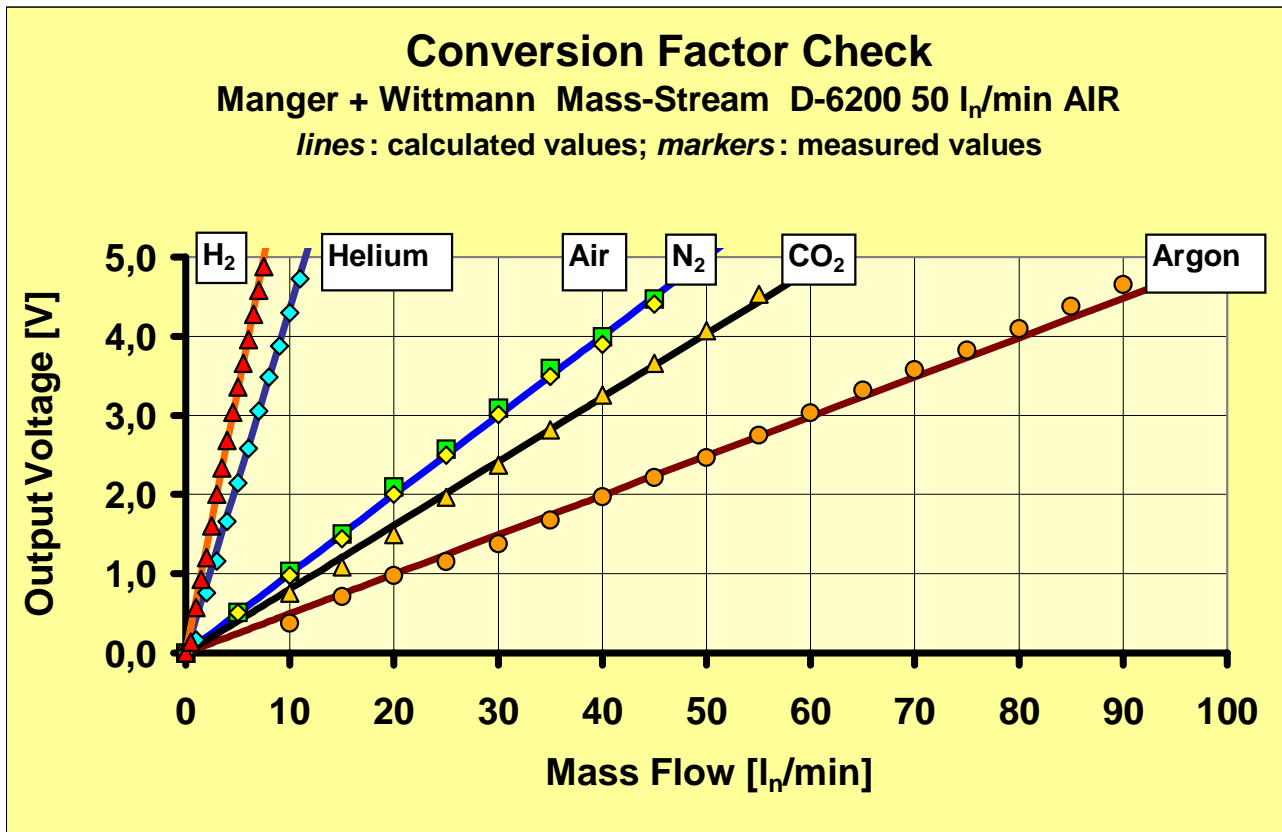

Figure 4. Typical measurement results obtained with a D6200 MFM for 50 l_n/min AIR

As can be seen in figure 4, there is a good correspondence between calculated and measured values. However, some deviations between theory and measurements occur. They can be explained as follows:

- n (equation (1)) was considered to be constant within the whole flow range, which is not true
- practical temperatures and pressures differed from the values used in the calculations.

The obtained measurement results lead to the specifications as shown in table 2.

Table 2. Specifications of Manger +Wittmann's D-6200 Mass Flow Meter

Flow range	5 l _n /min – 2000 l _n /min
Dynamic range	5 .. 100 %
Inaccuracy (air)	± 3 % F.S.
Repeatability	± 0.5 % F.S.
Response time	$\tau_{63\%} = 0.7$ s
Pressure sensitivity	0.3 % / bar typical (air)
Attitude sensitivity	0.3 % F.S. at 90° change typical (air)
Temperature sensitivity	± 0.3 % / °C
Zero adjustment	Gas dependent
Gas types	All gases compatible with materials chosen
Leak integrity	$< 2 \times 10^{-9}$ mbar l/s He
RFI	According to CE
Temperature range	0 .. 50 °C
Pressure	Max. 10 bar; higher on application
Supply voltage	24 V _{DC} ± 10 %
Output signal	0 .. 5 V _{DC} or 4 .. 20 mA

CONCLUSIONS

A new economical thermal mass flow meter based on constant temperature anemometry has been designed, constructed and characterised. The derived theoretical model of the heat transfer has been of great help in the development of the instrument, especially with respect to the calculation of the conversion factors between air and another gas.

Manger + Wittmann's D-6200 mass flow meter is now commercially available.

REFERENCES

- [1] H.H. Bruun, *Hot-Wire Anemometry, principles and signal analysis*, Oxford University Press, Oxford, UK, 1995
- [2] J.J. Feijen, *Inleiding tot de warmtetechniek*, Van Nijgh & Ditmar, Rijswijk, The Netherlands, 1987, *in Dutch*
- [3] G.J. de Bruin, *Warmteoverdracht en Stromingsleer 1a, 1b*, University of Twente, Enschede, The Netherlands, 1998, *in Dutch*
- [4] J.M. Smith, E. Stammers, L.P.B.M. Janssen, *Fysische Transport Verschijnselen I*, Delft University Press, Delft, The Netherlands, 1981, *in Dutch*

ACKNOWLEDGMENTS

The author would like to thank prof. dr. ir. D. Thoenes, ir. G.J. de Bruin and ir. W.C.M. Gorissen (all University of Twente) for their valuable contributions to the theoretical modelling of the sensor's heat transfer.