



Badger Meter Europa

Electromagnetic amplifier type ModMAG™ M1500

for all detectors

Description

The basic line of M1500 is provided with 24 VDC power supply, display, passive outputs and can be programmed via a serial port RS232 or 3 buttons. The device can be factory preconfigured and then just needs to be electrically connected on site. The M1500 is encased into a powder-coated aluminium diecast housing IP65 and has two M 20 screws. The basic line can be provided with a four-line LC display, a 115/230 VAC power supply and active pulse and analog outputs. The standard model M1500 is supplied with an analog output, two digital outputs for pulse and frequency as well as a digital input. With an accuracy of $\pm 0,5\%$ of actual flow ($> 0,5$ m/s) and flow measurements ranging between 0,03 and 12 m/s in both directions, the flow meter covers a great variety of applications.



Measuring principle

The operating principle of the electromagnetic flow meter is based on Faraday's law of magnetic induction: The voltage induced across any conductor, as it moves at right angles through a magnetic field, is proportional to the velocity of that conductor. The voltage induced within the fluid is measured by two diametrically opposed internally mounted electrodes. The induced signal voltage is proportional to the product of the magnetic flux density, the distance between the electrodes and the average flow velocity of the fluid.

Applications

The M1500 has been designed especially for applications in machinery plants, vehicles and batching processes. The applications range from DN 6 to DN 200 with the most various process connections like DIN flanges, dairy pipe connections, TriClamp®, etc.

Technical data

Power supply	24 VDC optional 115 / 230 VAC (50 / 60 Hz), 10 VA
Accuracy	$\pm 0,5\%$ of actual flow, $\geq 0,5$ m/s $\pm 2,5$ mm/s of actual flow, $< 0,5$ m/s
Repeatability	$< 0,1\%$ of full scale
Flow velocity	0,03 - 12 m/s
Conductivity	min. $5 \mu\text{S/cm}$ ($20 \mu\text{S/cm}$ for demineralized water)
Flow direction	bi-directional
Display	with LCD, 4 lines / 16 characters, backlit, actual flow, 3 totalizers, status display
Programming	RS232 or via 3 buttons
Interface	RS232 for measuring values and programming
Analog output	4 - 20 mA passive, optional active, flow direction is displayed upon a separate status output
Pulse output	passive, optional active, 2 open collectors, passive 24 VDC, 50 mA, max. 10 kHz
Frequency output	max. 10 kHz (open collector)
Status output	min./max. alarm, preselection, flow direction, error message, free configurable
Empty pipe detection	separate electrode
Low flow cut off	0-10%
Housing	Powder coated aluminium die cast
Protection class	IP65
Cable insertion	2 x M 20
Ambient temperature	-20 up to +60°C

Dimensions

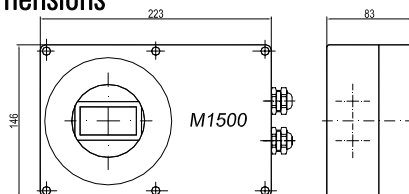

MID_M1500_Datenblatt_0704_e.doc 07/04

Badger Meter Europa GmbH - Nürtinger Strasse 76 - 72639 Neuffen (Germany)

Tel. + 49-7025-9208-0

Fax + 49-7025-9208-15

www.badgermeter.de

E-mail: badger@badgermeter.de

Detector type II

Flange process connection

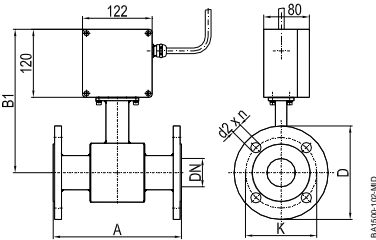
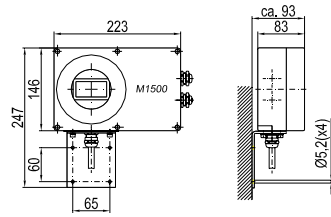

Wall mounted

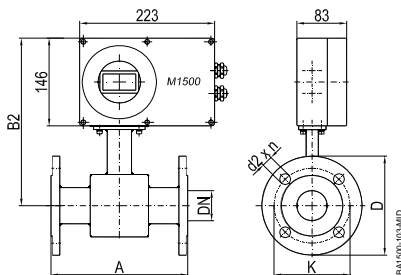

Remote version

The electromagnetic detector type II is not only available in a number of different flange process connections (DIN, ANSI, JIS, AWWA, etc.) but also in a number of liners like hard rubber, soft rubber, PTFE, PFA or Halar. Available in sizes from DN 6 to DN 200 and nominal pressures up to PN 100, the detector type II is best suited for a variety of applications in the industry and the water/waste water industry.

Technical data

Size	DN 6 – 200 (1/4" ... 8")		
Process connections	Flange: DIN, ANSI, JIS, AWWA, etc		
Nominal pressure	up to PN 100		
Protection class	IP65, optional IP68		
Min. conductivity	5 μ S/cm (20 μ S/cm for demineralized water)		
Liner materials	Hard/soft rubber	from DN 25	0 up to +80°C
	PFA	DN 6 – 40	-40 up to +150°C
	PTFE	DN 6 – 200	-40 up to +150°C
Electrodes materials	Hastelloy C (standard), Tantal Platinum / Gold plated, Platinum / Rhodium		
Housing	Carbon steel / optional stainless steel		
Lay length	DN 6 – 20	170 mm	
	DN 25 – 50	225 mm	
	DN 65 – 100	280 mm	
	DN 125 – 200	400 mm	

Dimensions (mm)

DN		A Std*	A ISO**	B1	B2	with ANSI-flanges			with DIN-flanges		
						Ø D	Ø K	Ø d2xn	Ø D	Ø K	Ø d2xn
6	1/4"	170	---	228	254	88,9	60,3	15,9 x 4	90	60	14 x 4
8	3/10"	170	---	228	254	88,9	60,3	15,9 x 4	90	60	14 x 4
10	3/8"	170	---	228	254	88,9	60,3	15,9 x 4	90	60	14 x 4
15	1/2"	170	200	238	264	88,9	60,3	15,9 x 4	95	65	14 x 4
20	3/4"	170	200	238	264	98,4	69,8	15,9 x 4	105	75	14 x 4
25	1"	225	200	238	264	107,9	79,4	15,9 x 4	115	85	14 x 4
32	1 1/4"	225	200	253	279	117,5	88,9	15,9 x 4	140	100	18 x 4
40	1 1/2"	225	200	253	279	127	98,4	15,9 x 4	150	110	18 x 4
50	2"	225	200	253	279	152,4	120,6	19 x 4	165	125	18 x 4
65	2 1/2"	280	200	271	297	177,8	139,7	19 x 4	185	145	18 x 4
80	3"	280	200	271	297	190,5	152,4	19 x 4	200	160	18 x 8
100	4"	280	250	278	304	228,6	190,5	19 x 8	220	180	18 x 8
125	5"	400	250	298	324	254	215,9	22,2 x 8	250	210	18 x 8
150	6"	400	300	310	336	279,4	241,3	22,2 x 8	285	240	22 x 8
200	8"	400	350	338	364	342,9	298,4	22,2 x 8	340	295	22 x 12

Standard

with ANSI-flanges

from DN 6 – 200

Lbs 150

with DIN flanges

from DN 6 – 200

PN 16

* Standard

**ISO 13359

Sanitary detector for Food

Process connections Tri-Clamp®, DIN 11851, ISO 2852, etc.

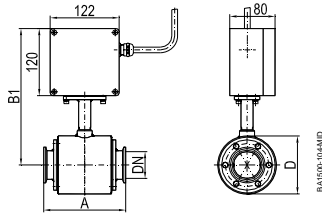
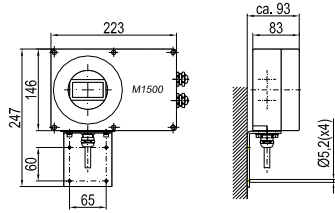

TriClamp®, wall mounted

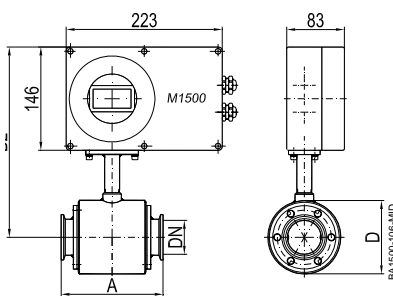

TriClamp®, remote version

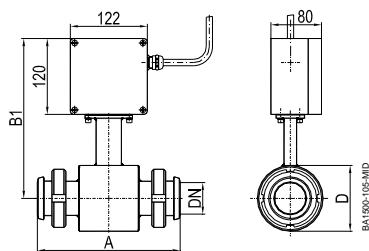
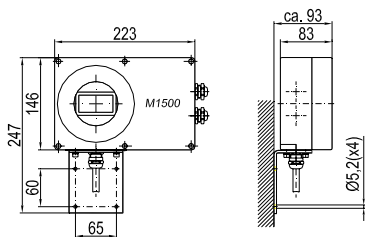

DIN11851, wall mounted

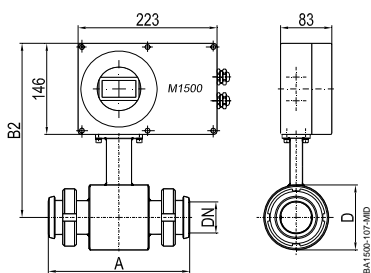

DIN 11851, remote version

The sanitary detector was developed for the flow measurement of liquid food. This model is available with Tri-Clamp®, DIN 11851, ISO 2852 process connections and also with any special connections (customer specifications). The sanitary detector is delivered in a stainless steel housing and with PTFE lining.

Technical data

Size	DN 10 - 100 (3/8" ... 4")		
Process connections	Tri-Clamp®, DIN 11851, ISO 2852, etc.		
Nominal pressure	PN 10		
Protection class	IP65, optional IP68		
Min. conductivity	5 µS/cm (20 µS/cm for demineralized water)		
Liner materials	PTFE	-40 up to +150°C	
Electrodes materials	Hastelloy C (Standard) Tantal Platinum / Gold plated Platinum / Rhodium		
Housing	Stainless steel		
Lay length	Tri-Clamp® connection	DN 10 - 50	145 mm
		DN 65 - 100	200 mm
	DIN 11851 connection	DN 10 - 20	170 mm
		DN 25 - 50	225 mm
	DN 65 - 100	280 mm	

Dimensions (mm) type Food Tri-Clamp®

DN		A	B1	B2	D
10	3/8"	145	228	254	74
15	1/2"	145	228	254	74
20	3/4"	145	228	254	74
25	1"	145	228	254	74
40	1 1/2"	145	238	264	94
50	2"	145	243	269	104
65	2 1/2"	200	256	282	129
80	3"	200	261	287	140
100	4"	200	269	295	156
PN 10					

Dimensions (mm) type Food DIN 11851

DN		A	B1	B2	D
10	3/8"	170	238	264	74
15	1/2"	170	238	264	74
20	3/4"	170	238	264	74
25	1"	225	238	264	74
32	1 1/4"	225	243	269	84
40	1 1/2"	225	248	274	94
50	2"	225	253	279	104
65	2 1/2"	280	266	292	129
80	3"	280	271	297	140
100	4"	280	279	305	156
PN 10					

Detector type III

Wafer connection

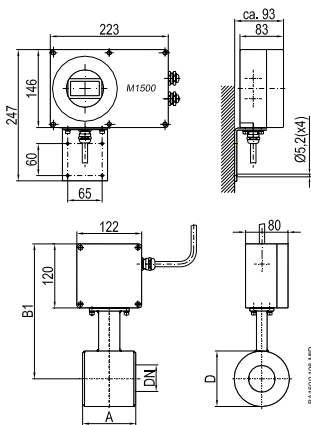

Wall mounted

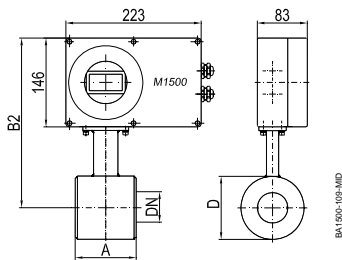

Remote version

Thanks to its very short lay length, the detector type III is often the right alternative to a lot of applications. Delivered with a PTFE liner, the detector type III has a standard nominal pressure of PN 40.

Technical data

Size	DN 25 - 100 (1" ... 4")	
Process connection	Wafer connection (in-between flange mounting)	
Nominal pressure	PN 40	
Protection class	IP65, optional IP68	
Min. conductivity	5 μ S/cm (20 μ S/cm for demineralized water)	
Liner materials	PTFE	-40 up to +150°C
Electrodes materials	Hastelloy C (Standard) Tantal Platinum / Gold plated Platinum / Rhodium	
Housing	Carbon steel / optional stainless steel	
Lay length	DN 25 - 50	100 mm
	DN 65 - 100	150 mm

Dimensions (mm)

DN		A	B1	B2	D
25	1"	100	238	264	74
32	1 ¼"	100	243	269	84
40	1 ½"	100	248	274	94
50	2"	100	253	279	104
65	2 ½"	150	266	292	129
80	3"	150	271	297	140
100	4"	150	279	305	156
PN 40					